

OPERATING INSTRUCTIONS, PARTS LIST & USER MANUAL



**14" Core Cutting Saw
Model #PEF1453**

CORE CUTTING PROCEDURE APPLICATION CHART FOR CORE CUTTING BLADES

MODEL #VHC24 SEGMENTED

USED FOR CUTTING VERY HARD CORE, SUCH AS CHERT, JASPERITE, QUARTZITE, HARD GRANITES, ETC. IF YOU USE THIS BLADE FOR CUTTING SOFTER CORE, IT MAY WEAR OUT PREMATURELY.

MODEL #HC44 SEGMENTED OR #CCRB14P CONTINUOUS RIM

USED FOR CUTTING HARD CORE, SUCH AS RHYOLITE, GRANITE, SILICIFIED VOLCANICS, ETC. IF YOU USE THIS BLADE FOR CUTTING SOFTER / ABRASIVE CORE, IT MAY WEAR OUT PREMATURELY.

MODEL #CC34 SEGMENTED (#SCQ14) OR #CCRB14 CONTINUOUS RIM

USED FOR CUTTING REGULAR CORE SUCH AS BASALT, DIORITE, DIABASE, GABRO, DOLOMITE, WEATHERED GRANITE, SERPENTINE, AND PERIDOTITE. IF YOU USE THIS BLADE FOR CUTTING SOFTER/ABRASIVE CORE, IT MAY WEAR OUT PREMATURELY. IF YOU USE THIS BLADE FOR HARDER CORE, IT MAY GO DULL AND NOT WANT TO CUT.

MODEL SC54 SEGMENTED

USED FOR CUTTING SOFT/ABRASIVE CORE SUCH AS CONGLOMERATES, SHALES, LIMESTONE, SILICA AND SULPHIDES. IF YOU USE THIS BLADE FOR CUTTING HARDER CORE, IT MAY GO DULL AND NOT WANT TO CUT.

NOTE :

ENSURE BLADES ARE MOUNTED ON SAW SO THEY TURN IN THE CORRECT DIRECTION.

CAUTION :

WHEN SAWING, EASE CORE INTO BLADE, AFTER CONTACT HAS BEEN MADE, THEN APPLY PRESSURE.

ENSURE THAT CORE IS SECURED SO AS NOT TO MOVE WHILE BEING CUT. IF CORE MOVES AND BLADE IS BENT SIDEWAYS, LOSS OF SEGMENTS COULD OCCUR.

OPERATION

Fitting the Blade:

- The blade rotates in a “down-cut” direction. This means that the front of the blade is moving downward while the rear of the blade is moving upward.
- Mount the Blade (DD) so that arrow on blade rotates in this “down-cut” direction. Blade (DD) can be installed / removed by the 9" (9 mm) end of the Wrench (LL) provided.

NOTICE

Note that Blade Shaft Capscrew (BB) has RIGHT HAND THREADS. Installation of the wrong capscrew could damage the blade shaft!

Wrench (LL) provided (or one of your own) loosen the Capscrew (BB) by turning it CounterClockwise.

1. Remove the outer Flange (CC). Make sure Outer Flange Inner Flange (EE), and Arbor (FF) are clean and not damaged.
- Mount Blade (DD) to arbor. Install Outer Flange (CC) and tighten Capscrew (BB) by turning it in a Clockwise direction (Right Hand Thread). Use Wrench (LL) to firmly tighten the Capscrew (BB) to arbor shaft.
- After mounting the Blade (DD), it should align over the top wooden insert in the Conveyor Cart (C). During operation unit, the blade can, and should, pass into the wooden but NOT into the cast aluminum part of the Conveyor Cart
- If this is not true, loosen the setscrews that secure the Bearings (H) to the Head Platform Assembly (B). Position Head Platform Assembly (B) to the left or right until the Diamond Blade (DD) is aligned over the top of the wooden then re-tighten the Bearing (H) setscrews.

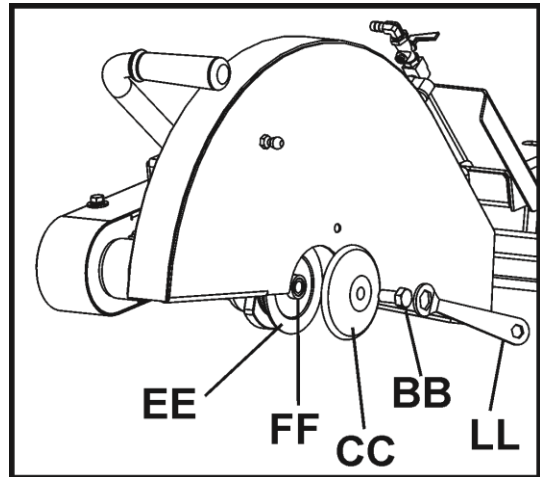

using

1. Using the

(CC),

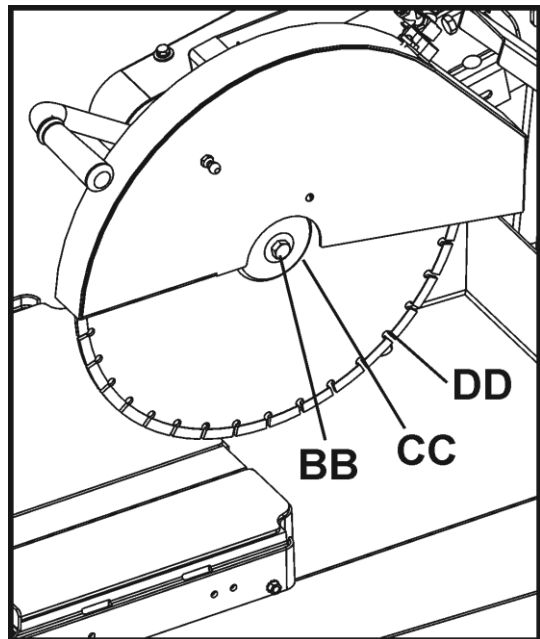

Install

of the of this insert, (C).

the insert,

• **WARNING!**

- Pothier “Wet” diamond blades MUST be used with water!
- If cutting without water use only diamond blades that are intended to be used dry (without water).
- DO NOT use Abrasive Blades WITH water!
- Always use respiratory protection when dry sawing!

OPERATION

Wet Configuration:

- Fill the water reservoir pan [Pan Weldment (A)] with water to within 1 inch (25 mm) of the top. Be sure that the Electric Water Pump Intake (U) is fully immersed in water at all times. Keep the intake screen clean and free of sludge, slurry, or other foreign material.

Cutting Operations:

- Place material on Conveyor Cart (C) and move conveyor cart to the front of the saw so that the blade DOES NOT contact the material.
- Cutting Methods: This unit allows three methods for the blade to contact the material:
 1. **Fixed Head:** Position Blade (D) to desired height, using Blade Height Control Handle (P). Turn Handle (P) clockwise or counter-clockwise to raise or lower Blade (D). Material can then be pushed into blade. This method is best for reduced blade wear.
 2. **Pivot Using Hand Grip:** Hold the Hand Grip (L) and lower the blade into the material. Blade will return to upper position when force is released.
 3. **Pivot Using Foot Pedal (W):** Push down Foot Pedal (W) to lower blade into material. Blade will return to upper position when force is released.

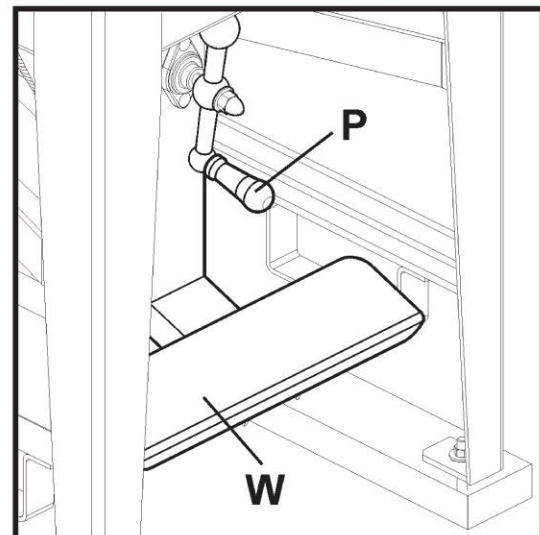
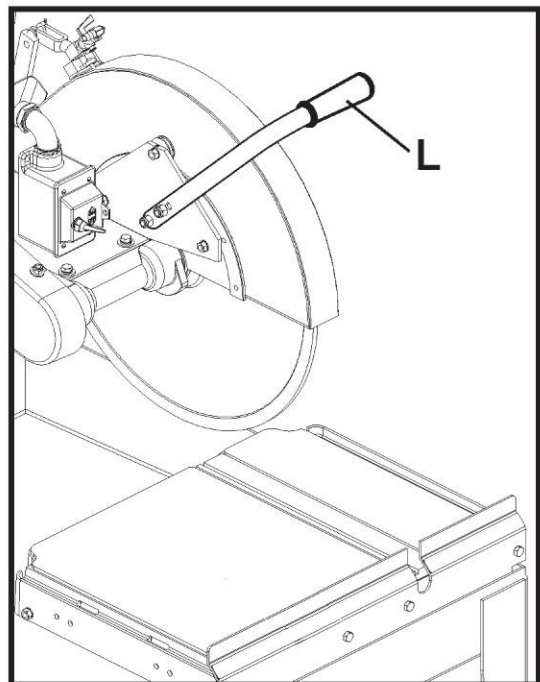
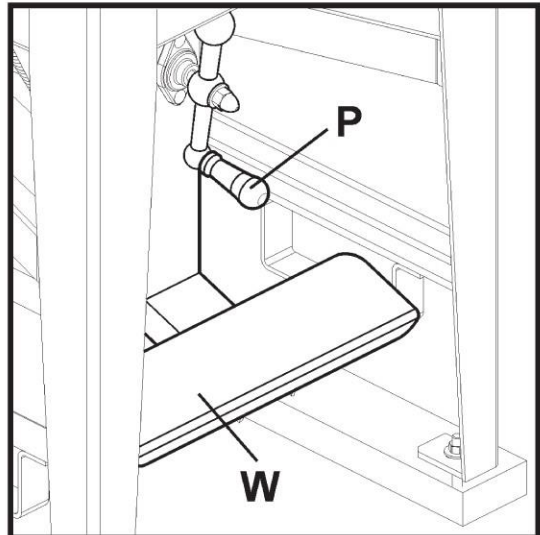

OPERATION

Start / STOP of Machine:

- Start the electric motor by turning the Power Switch (RR) to the "ON" position.
- Open the Water Valve (T) fully, and check the
- Cut the material using one of the Cutting Methods described in the above section.

WARNING!

Keep hands clear of rotating blade during operation!
READ ALL SAFETY WARNINGS before operating this machine!

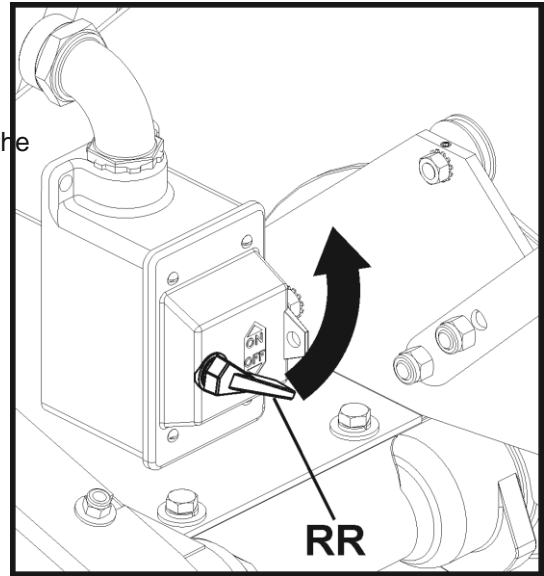

Stopping the Machine:

Stop machine by turning Power Switch (RR) to OFF position.

WARNING!

ALWAYS set Power Switch (RR) to OFF position BEFORE connecting to power source! Electric motor will run if Power Switch (RR) is in ON position.

WARNING!

STOP Machine, and Wait for all blade movement to stop before removing material from machine!

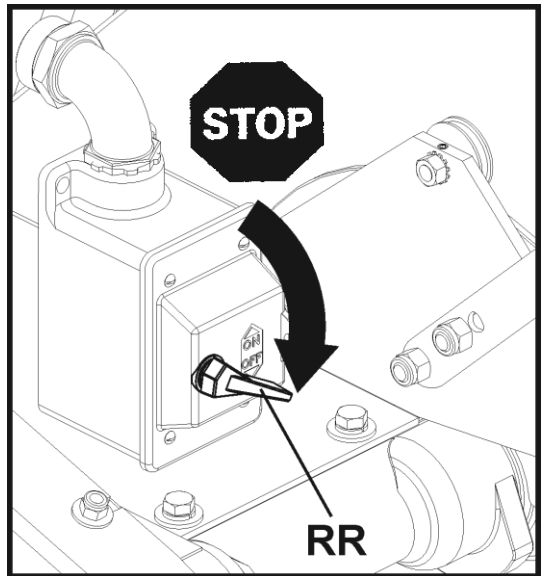

Incidents During Operation:

- If motor stops during operation, check the following:
 - Interruption to electrical connection: Check all electrical connections.
 - Manual Overload switch has been tripped: Single phase, 0 Hertz motors are equipped with a manual overload Reset Button (PP). If motor stops because of an electrical overload and overload Reset Button (PP) trips, turn motor Power Switch (RR) to OFF position. Allow motor to cool for to 0 minutes, then push the Reset Button (PP). A click indicates that motor is reset and ready for operation. Restart motor by turning Power Switch (RR) to ON position.

Head Assembly

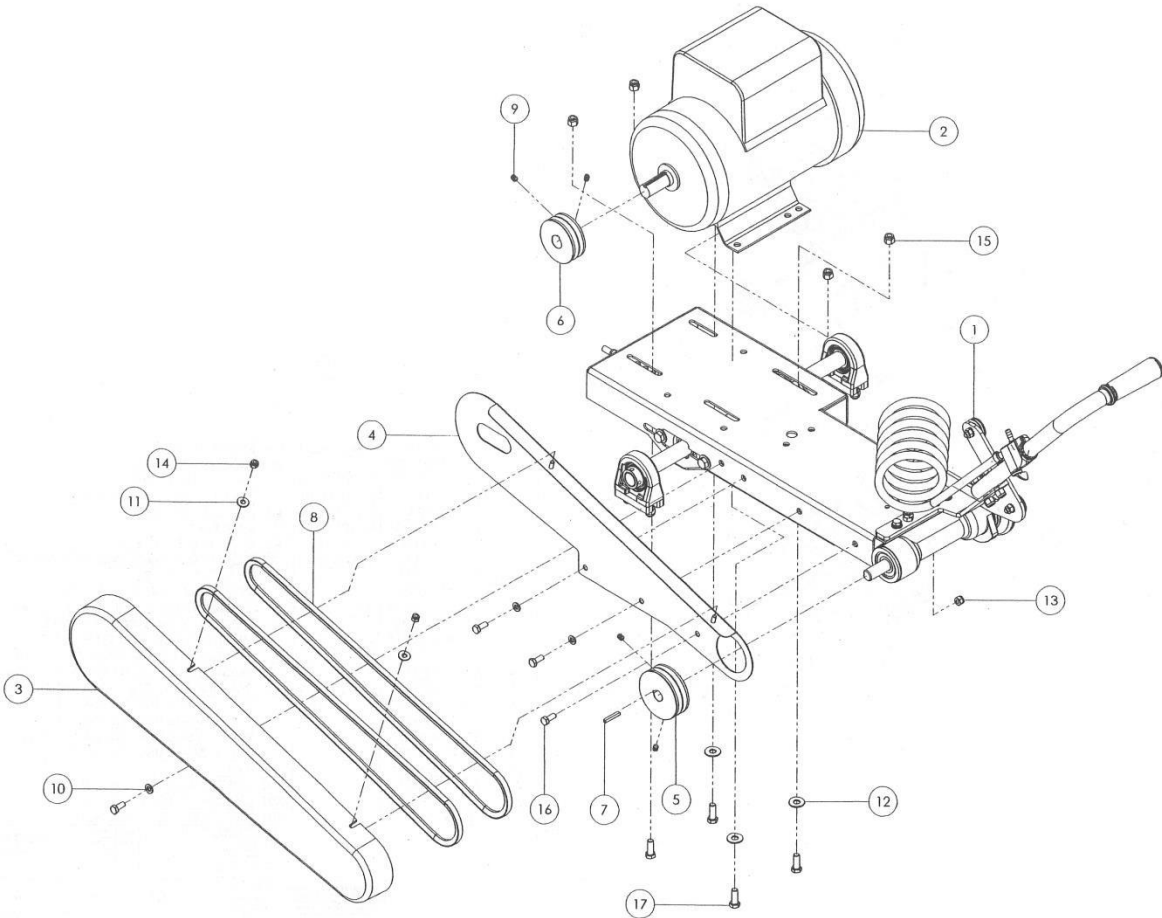

ITEM	QTY	PART NO	DESCRIPTION
1	1	030822	CART WHEEL
2	1	169622	MOTOR: 5HP 3450 208-230/60/1
		169623	MOTOR: 5HP 3450 208-230/460/60/3
		169624	MOTOR: 5HP 2850 220/50/1
		169625	MOTOR: 5HP 2850 220-380/50/3
3	1	030831	BELT GUARD
4	1	510154301	INNER BRACKET, BELT GUARD
5	1	030900	PULLEY, 2G3V 3.35 - .750 BORE
6	1	030905	PULLEY, 2G3V 2.25 - .875 BORE
7	1	020062	KEY, .1875 SQ X 1.25
8	2	163683	V-BELT: 3VX530
9	4	91375A576	SHSS, .3125-18 X .375
10	3	539990187	WASHER, LOCK, SPLIT TYPE, .312 REG STL PLTD
11	2	541205764	WASHER, FLAT, .25 STD, PLATED
12	3	020743	WASHER, FLAT, .375 STD, PLATED
13	1	539990717	.3125-18UNC HEX LOCK NUT
14	2	539976978	.250-20UNC HEX LOCK NUT
15	4	539976979	.375-16UNC HEX LOCK NUT
16	4	539976934	HHCS .3125-18UNC, STL, GR 5, .75 LG
17	4	539990563	HHCS .375-16UNC, STL, GR 5, 1.00 LG

Upper Platform

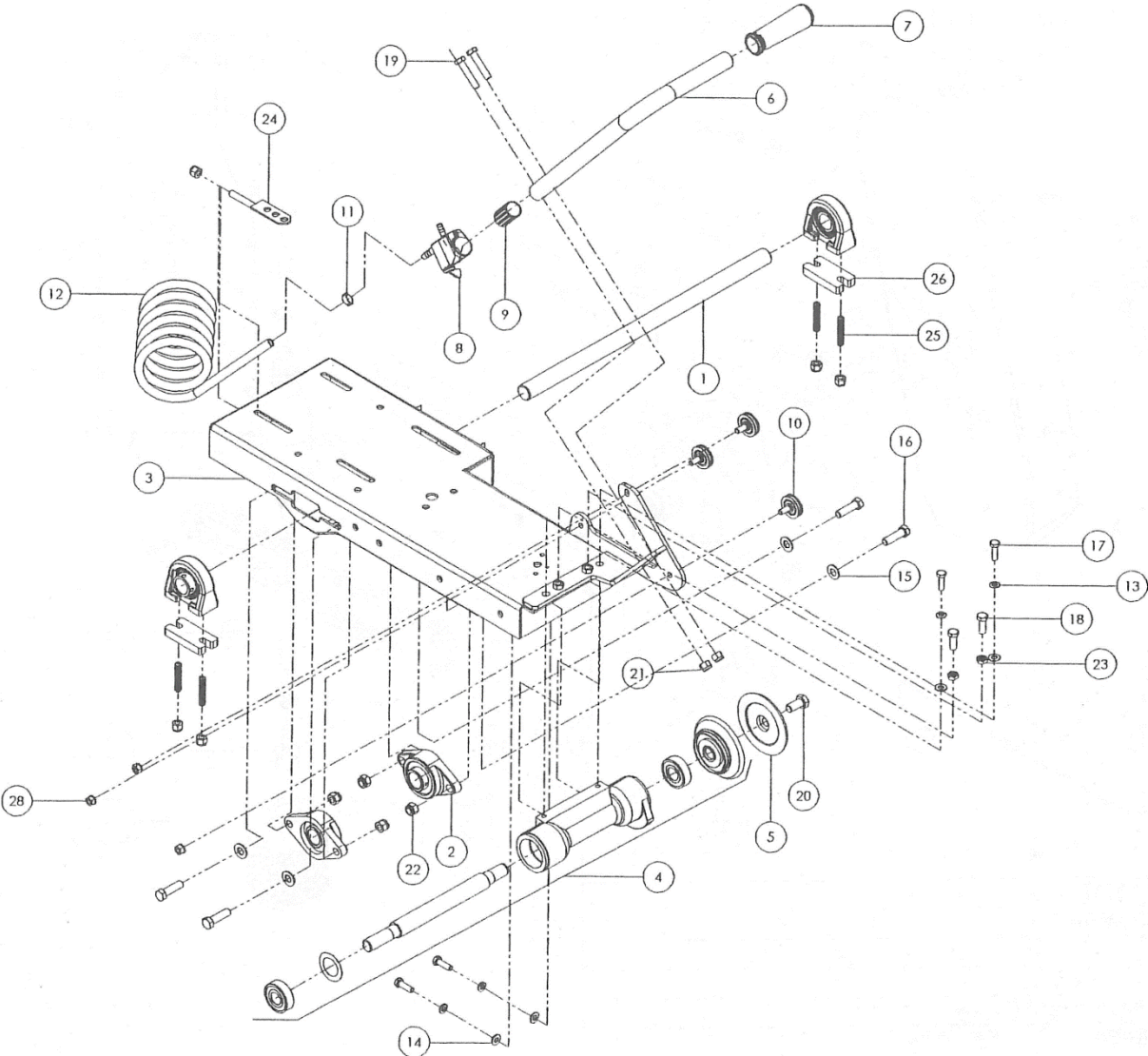

ITEM	QTY	PART NO	DESCRIPTION
1	1	510166001	SHAFT, 1" COUNTER DRIVE
2	2	510262101	BEARING, 1.00" DIA. 2-BOLT FLANGE
3	1	510161907	PLATFORM WELDMENT
4	1	195021	BLADESHAFT W/ HSG, GM, B/M
5	1	030951	FLANGE, OUTER
6	1	510260301	HANDLE
7	1	542139568	HANDLE GRIP
8	1	506386012	VALVE ASSY
9	1	537204201	CONDUIT, GREY PVC
10	3	030822	CART WHEEL
11	1	541200467	CLAMP, POINTER ROPE
12	1	523120305	VINYL TUBING, 3/8" I.D. X 64"
13	4	539990187	WASHER, LOCK, .312 REG, STL, PLTD
14	4	539990188	WASHER, FLAT, .313, NARROW, PLTD
15	4	177816	WASHER, FLAT, .438, NARROW, PLTD
16	4	541204969	HHCS .4375-14UNC, STL, GR 5, 1.50 LG
17	4	541205197	HHCS .3125-24UNC, STL, GR 5, 1.00 LG
18	2	168133	HHCS .375-24UNC, STL, GR 5, 1.00 LG
19	2	539990730	HHCS .375-16UNC, STL, GR 5, 1.75 LG
20	1	020378	HHCS .500-20UNC, STL, GR 5, 1.00 LG
21	7	539976979	.375-16UNC HEX LOCK NUT
22	4	020210	.4375-14UNC HEX LOCK NUT
23	2	020171	NUT, HEX JAM THIN .375-24 Z/P
24	1	177696	DRAW BOLT, .375-16UNC
25	4	522676403	SHSS, 3/8-16UNC X 2" LG
26	2	510179302	SPACER, BEARING
27	2	045241	BEARING, PILLOW BLOCK 1"
28	3	032366	NUT, KEPS, .3125-18UNC

Lower Platform

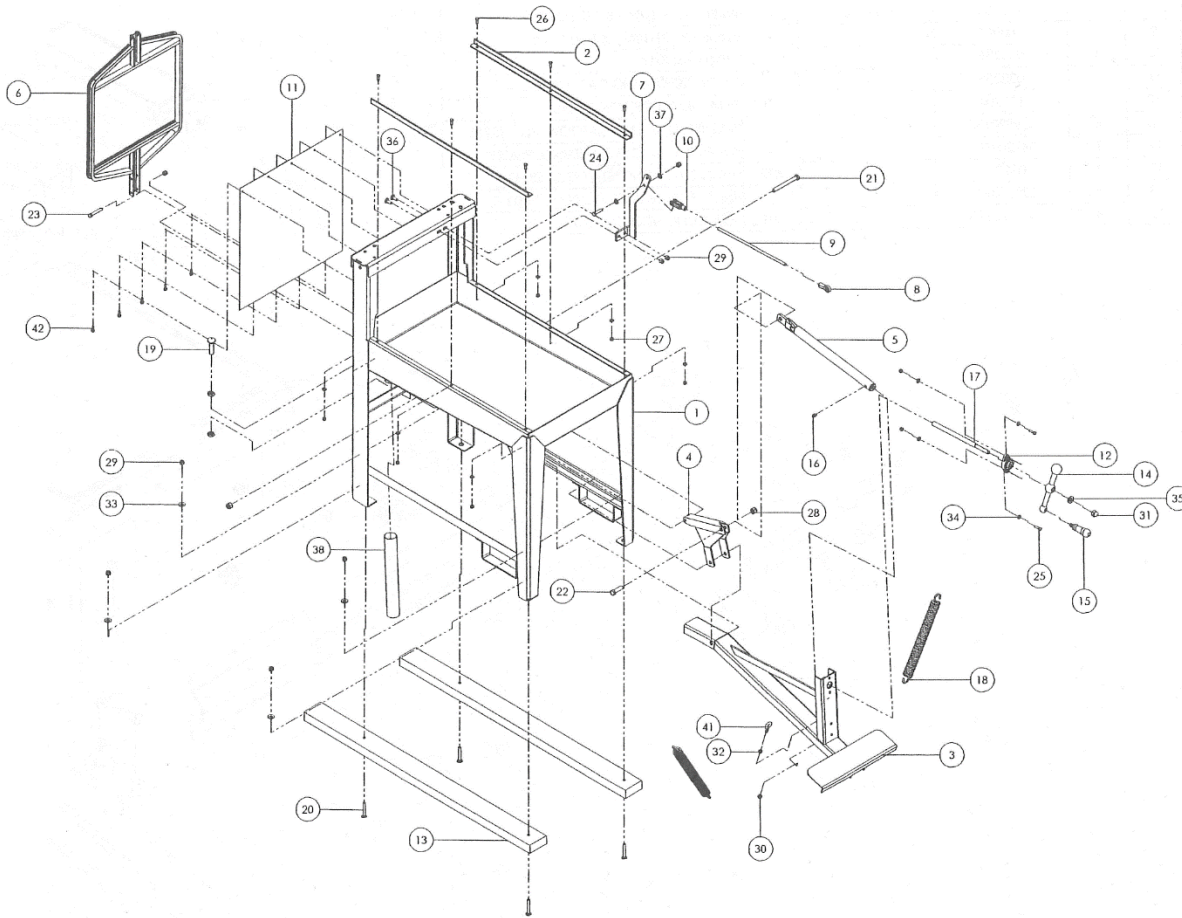

ITEM	QTY	PART NO	DESCRIPTION
1	1	510154813	FRAME
2	2	510140802	CART RAIL
3	1	542205352	FOOT PEDAL WELDMENT
4	1	510190601	YOKE, TILT
5	1	510190201	LINKAGE, ADJUSTMENT
6	1	542195274	TILT FRAME WELDMENT
7	1	510179604	BRACKET, STAY LEVEL ANCHOR
8	1	510179301	END, R.H. ROD
9	1	510179401	ROD, LINK
10	1	060460	YOKE, EBERHARD 4A.375 TAP X .375
11	1	521950902	SPLASH CURTAIN
12	1	542190434	BEARING, .5 ID, 2-BOLT FLANGE
13	2	542030884	SUPPORT, SKID, 2 X 4 X 47.5"
14	1	032242	HANDLE, CAST MACHINED
15	1	032250	HANDLE ASSY, REVOLVING
16	1	040139	GREASE FITTING, #1610
17	1	032570	SCREW, ADJUSTMENT
18	2	139581	SPRING
19	1	020024	CB, .625-11 X 2.5
20	4	020022	CB, .375-16 X 2.5
21	1	166422	HHCS, .500-13UNC, STL, GR 5, 4.75 LG
22	1	541204644	HHCS, .500-13UNC, STL, GR 5, 1.75 LG
23	1	020365	HHCS, .375-16UNC, STL, GR 5, 2.25 LG
24	1	539990655	HHCS, .375-16UNC, STL, GR 5, 1.50 LG
25	2	539977761	HHCS, .250-20UNC, STL, GR 5, 1.00 LG
26	6	539990580	HHCS, .250-20UNC, STL, GR 5, .75 LG
27	8	539976978	HEX LOCK NUT, .250-20UNC
28	2	539101331	HEX LOCK NUT, .50-13UNC
29	8	539976979	HEX LOCK NUT, .375-16UNC
30	1	539990717	HEX LOCK NUT, .3125-18UNC
31	1	542020211	HEX ACORN NUT, .500-13UNC
32	1	539990196	HEX JAM NUT, .3125-18UNC
33	4	020743	WASHER, FLAT, .375, STD, PLATED
34	10	539990055	WASHER, FLAT, .25, NARROW, PLATED
35	1	539990250	WASHER, FLAT, .50, NARROW, PLATED
36	2	170150	CB, .375-16 X 2.5 Z/P
37	2	539990122	WASHER, FLAT, .375, STD, PLATED SAE
38	1	032342	DRAIN HOSE, 1.75 I.D. X 14"
39	1	539300092	ANSI WOODRUFF KEY NO 405 (#5)
40	2	020175	HEX JAM NUT, THIN .625-11 Z/P
41	1	9489T26	BOLT, EYE .3125-18 X 1 Z/P
42	5	96024A420	HWHSTS, .25-20 X .75 THPE F Z/P

Blade Guard Assembly

(Part Number 510437339)

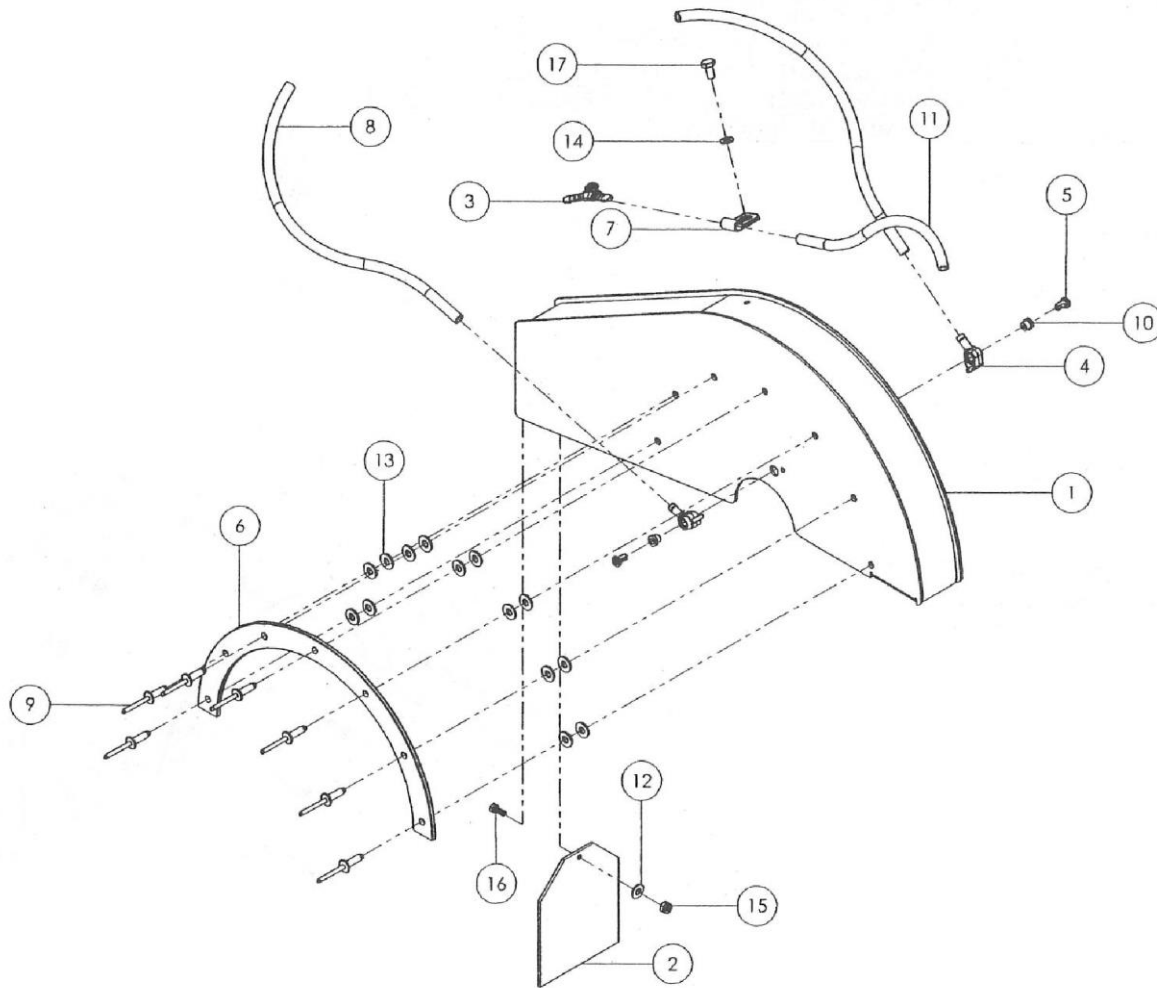

ITEM	QTY	PART NO	DESCRIPTION
		510437339	BLADE GUARD, COMPLETE
1	1	510259310	BLADE GUARD ONLY, ELECTRIC
2	1	169365	FLAP, SPLASH, CORRUGATED
3	1	506328701	HOSE FITTING, Y-TUBE
4	2	504634501	HOUSING
5	2	504634601	SCREW
6	1	505407702	TRACK RING
7	1	166672	CLAMP, VINYL COATED, 1/4 X 5/16
8	2	522981809	TUBING, 6MM I.D. X 330MM
9	7	020701	POP RIVET, USM #SD88BS
10	2	510190701	NIPPLE, MODIFIED
11	1	522981803	TUBING, 6MM I.D. X 229MM
12	1		WASHER, FLAT, .188 STD, PLTD
13	14	539990055	WASHER, FLAT, .25 NARROW, PLTD
14	1	539990052	WASHER, LOCK, .25 REG, STL, PLTD
15	1	020194	HEX LOCK NUT, 10-24UNC
16	1	93075A242	HHMS, #10-24UNC X .5, GR 5 Z/P
17	1	539990071	HHCS .250-20UNC, STL, GR 5, .50 LG

Conveyor Cart Assembly & Accessories

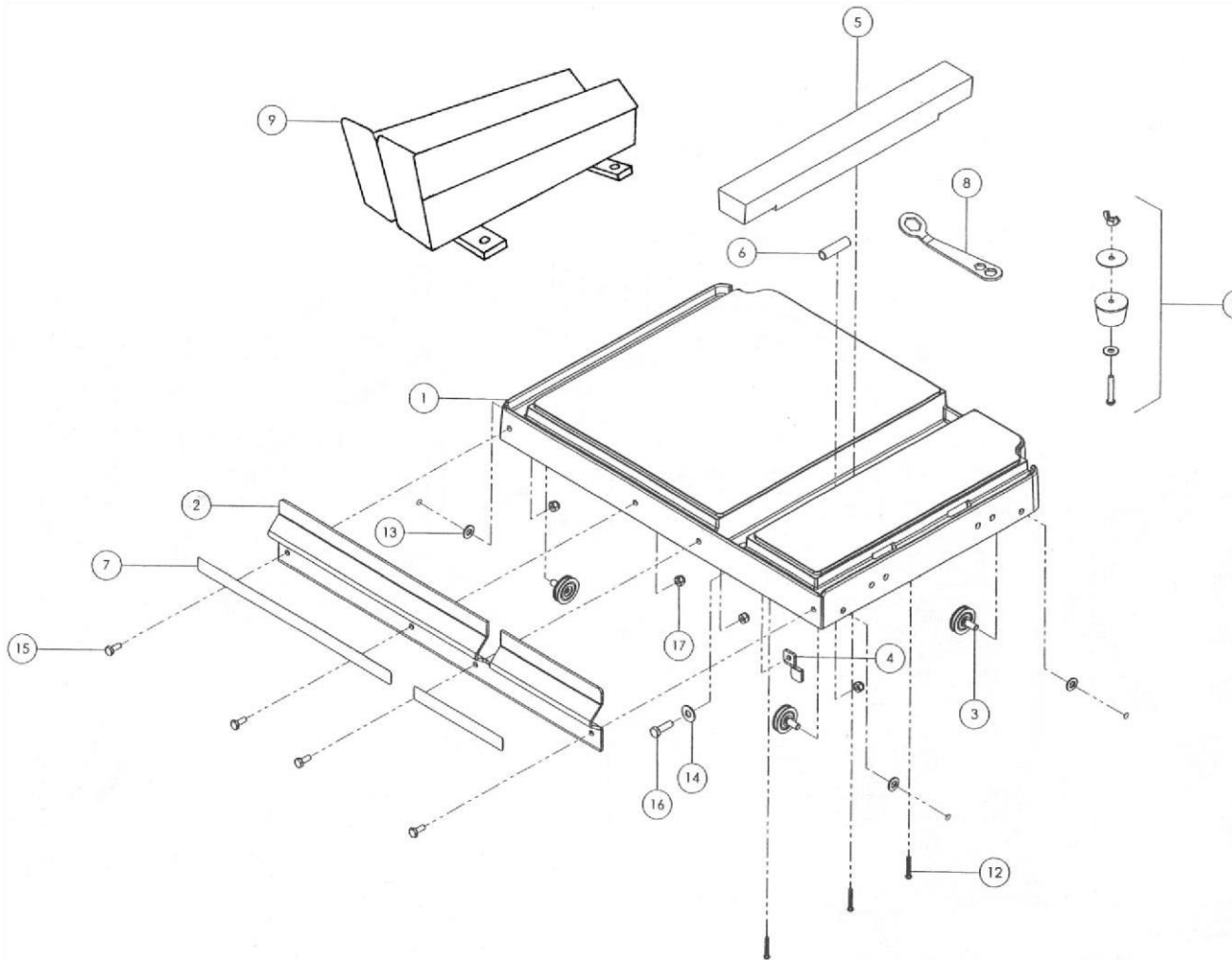

ITEM	QTY	PART NO	DESCRIPTION
		437323	CART, CONVEYOR, COMPLETE
1	1	186000	CART, CONVEYOR W/ MOLDED TOP
2	1	186057	BACK STOP
3	4	030822	CART WHEEL
4	1	542193951	CART STOP
5	1	542177894	WOOD INSERT, 15.88" LG
6	1	170038	VINYL TUBING, 3/8" I.D.
7	1	177976	DECAL, RULER
8	1	177383	WRENCH, 3/4", 9/16" & 1/2" BOX END
9	1	073114	CRADLE, CORE CUTTING, 16"
10	1	030386	DRAIN PLUG ASSY
12	3	177904	RHMS, #8 X 1.25" LG, SLTD
13	4	539990188	WASHER, FLAT, .313 NARROW, PLTD
14	1	541204780	WASHER, FLAT, .313 STD, PLTD
15	4	020301	HHCS .250-20UNC, STL, GR 5, .63 LG
16	1	539990209	HHCS .3125-18UNC, STL, GR 5, 1.00 LG
17	4	541204836	.250-20UNC HEX LOCK NUT

Blade Shaft Assembly

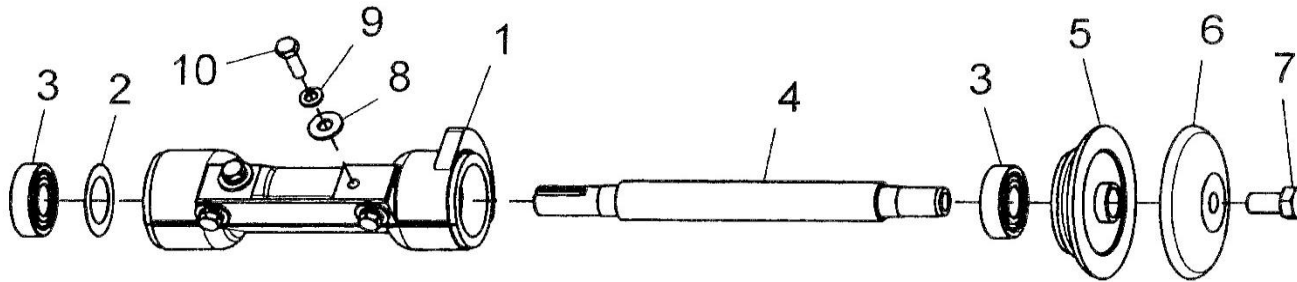

ITEM	QTY	PART NO	DESCRIPTION
	1	205437	BLADE SHAFT ASSEMBLY, COMPLETE
1	1	195020	HOUSING, BLADE SHAFT
2	1	030004	WASHER, SPRING, FINGER LOAD
3	2	139273	BEARING W/ SEAL
4	1	195017	BLADE SHAFT
5	1	177973	COLLAR, INNER
6	1	030951	COLLAR, OUTER
7	1	020378	CAPSCREW, HEX HD .500-20UNF X 1.00 (ELECTRIC)
8	4	020742	WASHER, FLAT, .313 DIA
9	4	020785	WASHER, LOCK, SPLIT, .313 DIA
10	4	020314	CAPSCREW, HEX HD .312-24UNF X .75

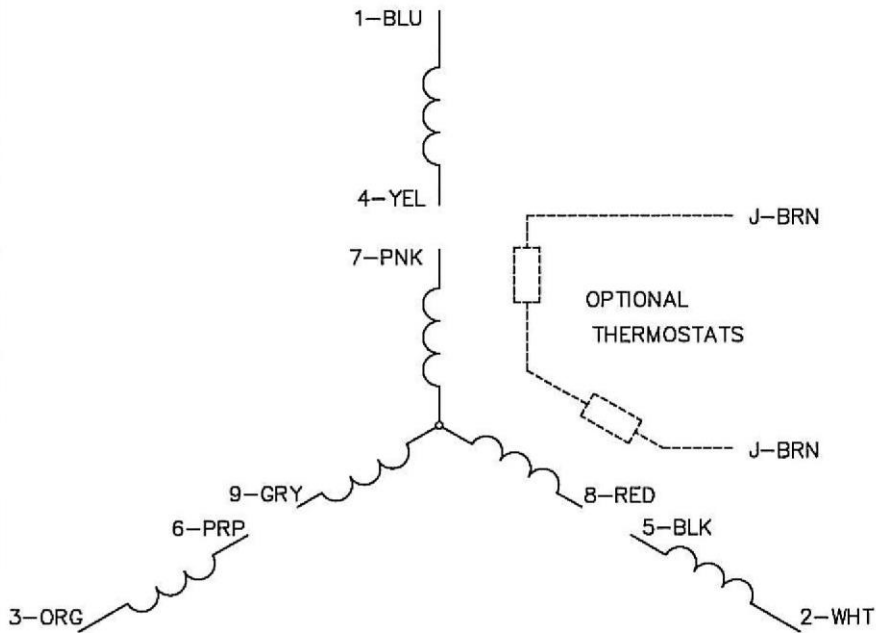

LOW VOLTAGE (2Y)

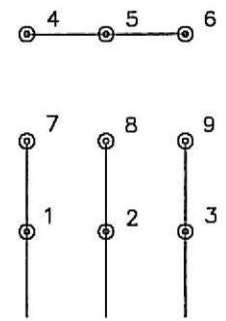

LINE

HIGH VOLTAGE (1Y)

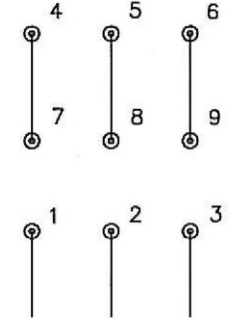

LINE

NOTES:

1. INTERCHANGE ANY TWO LINE LEADS TO REVERSE ROTATION.
2. OPTIONAL THERMOSTATS ARE PROVIDED WHEN SPECIFIED.
3. ACTUAL NUMBER OF INTERNAL PARALLEL CIRCUITS MAY BE A MULTIPLE OF THOSE SHOWN ABOVE.
4. LEAD COLORS ARE OPTIONAL. LEADS MUST ALWAYS BE NUMBERED AS SHOWN.

REV. DESC: REVISE TO SHOW OPTIONAL COLORS			
REV. LTR: E	BY: JLP	REVISED: 01/19/99 10:15	TDR: 0171435
900000		FILE: AAA00005140	MDL: -
		MTL: -	

BALDOR ELECTRIC Co.

3PH, DV, 9 LEADS

SAFETY INSTRUCTIONS

WARNING!	
 	Before starting up machine make sure you completely read these instructions. Be familiar with operation of the machine before operation!

 	 	 	The operator must wear protective clothing appropriate to the work he is doing.

	Any persons not involved in the work should leave the area.
--	---

	MANDATORY		INDICATION INFORMATION INSTRUCTION
--	------------------	--	---

	WARNING		PROHIBITION
--	----------------	--	--------------------

	The working area must be completely clear, well lit and all safety hazards removed.
--	---

These signs will give advice for your safety

	Any persons not involved in the work, should leave the area.
--	--

Before leaving our factory every machine is thoroughly tested.

Follow our instructions strictly and your machine will give you long service in normal operating conditions.

WARNING!
Always make sure the saw is connected to a properly grounded electrical outlet. Failure to comply with this warning could result in serious bodily injury or death!

WARNING!
Use ONLY Reinforced Abrasive Blades or Diamond Blades with this machine. Use ONLY blades marked with a maximum operating speed greater than the blade shaft speed. DO NOT use carbide tipped, wood cutting, or circular saw blades with this machine. Conventional "Wet" diamond blades MUST be used with water. DO NOT use conventional "Wet" diamond blades without water. Using conventional "wet" diamond blades without water can result in injury or death of the operator or persons in the work area! Before performing any maintenance, ALWAYS locate the machine on a level surface with the engine / motor OFF and the start switch in the OFF position, and the power source disconnected.

SAFETY INSTRUCTIONS

WARNING!

HEARING HAZARD!
DURING NORMAL USE OF
THIS MACHINE,
OPERATOR MAY BE
EXPOSED TO A NOISE
LEVEL EQUAL OR
SUPERIOR TO **85 dB (A)**

DUST WARNING

Cutting, especially when DRY cutting, generates dust that comes from the material being cut, which frequently contains silica. Silica is a basic component of sand, quartz, brick clay, granite and numerous other minerals and rocks. Exposure to excessive amount of such dust can cause:

- Respiratory diseases (affecting your ability to breathe), including chronic bronchitis, silicosis and pulmonary fibrosis from exposure to silica. These diseases may be fatal;
- Skin irritation and rash; and
- Cancer according to NTP* and IARC*

* National Toxicology Program, International Agency for Research on Cancer

Take precautionary steps

- Avoid inhalation of and skin contact with dust, mist and fumes;
- Wet cut when feasible, to minimize dust;
- Wear and ensure that all bystanders wear appropriate respiratory protection such as dust masks designed to filter out microscopic particles.
(See OSHA 29 CFR Part 1910.1200)

SAFETY FIRST!



**WARNINGS
DO's AND DO NOT's**



WARNING: FAILURE TO COMPLY WITH THESE WARNINGS AND OPERATING INSTRUCTIONS COULD RESULT IN DEATH OR SERIOUS BODILY INJURY.

DO

- DO** read this entire operator's manual before operating this machine. Understand all warnings, instructions, and controls.
- DO** keep all guards in place and in good condition.
- DO** wear safety approved hearing, eye, head and respiratory protection.
- DO** read and understand all warnings and instructions on the machine.
- DO** read and understand the symbol definitions contained in this manual.

- DO** keep all parts of your body away from the blade and all other moving parts.
- DO** know how to stop the machine quickly in case of emergency.
- DO** shut off the engine and allow it to cool before refueling.
- DO** inspect the blade, flanges and shafts for damage before installing the blade.

- DO** use only Pothier diamond blades manufactured for use on core cutting saws.
- DO** use only blades marked with a maximum operating speed greater than the blade shaft speed. Verify speed by checking blade shaft rpm and pulley diameters and blade flange diameters.
- DO** verify saw drive configuration by checking blade shaft RPM, pulley diameters, and blade flange diameter.
- DO** read all safety materials and instructions that accompany any blade used with this machine.
- DO** inspect each blade carefully before using it. If there are any signs of damage or unusual wear, **DO NOT USE THE BLADE.**
- DO** mount the blade solidly and firmly. Wrench tighten the arbor nut.

- DO** make sure the blade and flanges are clean and free of dirt and debris before mounting the blade on the saw.
- DO** use wet cutting diamond blades with a 1" (diameter arbor only). Never use damaged or worn blade flanges.

- DO** use the correct blade for the type of work being done. Check with blade manufacturer if you do not know if blade is correct.
- DO** operate this machine only in well ventilated areas.
- DO** instruct bystanders on where to stand while the machine is in operation.
- DO** establish a training program for all operators of this machine.
- DO** clear the work area of unnecessary people. Never allow anyone to stand in front of or behind the blade while the engine is running.
- DO** make sure the blade is not contacting anything before starting the engine.
- DO** always tie down the machine when transporting.
- DO** use caution and follow instructions when setting up or transporting the machine.
- DO** have all service performed by competent service personnel.
- DO** verify the blade arbor hole matches the machine spindle before mounting the blade.
- DO** make sure the gas caps of the machine and the fuel can are properly tightened before starting the engine. Move fuel can at least 0 feet from machine after fueling.
- DO** clean the machine after each day's use.
- DO** remove adjusting keys and wrenches from tool before turning it on.
- DO** keep the handles dry, clean and free of oil and dirt.
- DO** carefully maintain and clean for better and safer performance. Follow instructions for changing accessories. Inspect tool cords periodically and, if damaged, have repaired by authorized service facility.

- DO** use the proper blade flange size for each blade size. Never use damaged or worn blade flanges.

- DO** use caution when handling fuel.

- DO only cut in a straight line.
- DO make sure electric powered machines are plugged into a properly grounded circuit.
- DO make sure power cords are the proper size and in good condition.
- DO follow all electrical codes in your area.
- DO use correct voltage and proper extension cords. Never carry tool by cord or yank it to disconnect it from receptacle. Keep cord away from heat, oil and sharp edges.
- DO disconnect tools from power source when not in use, before servicing and, when changing accessories.
- DO carefully maintain and clean for better and safer performance. Follow instructions for changing accessories. Inspect tool cards periodically and, if damaged, have repaired by authorized service facility.
- DO always give a copy of this manual to the equipment user. For extra copies, call (604) 946-3811.

SAFETY FIRST!



WARNING: FAILURE TO COMPLY WITH THESE WARNINGS AND OPERATING INSTRUCTIONS COULD RESULT IN DEATH OR SERIOUS BODILY INJURY.

DO NOT

- DO NOT operate this machine unless you have read and understood this operator's manual.
- DO NOT operate this machine without the blade guard, or other protective guards in place.
- DO NOT leave this machine unattended while the engine is running.
- DO NOT work on this machine while the engine is running.
- DO NOT operate this machine when you are tired or fatigued.
- DO NOT use a wet blade without adequate water supply to the blade.
- DO NOT exceed maximum blade speed shown for each blade size. Excessive speed could result in blade breakage.
- DO NOT operate the machine if you are uncertain of how to run the machine.
- DO NOT use damaged equipment or blades.
- DO NOT touch or try to stop a moving blade with your hand.
- DO NOT cock, jam, wedge or twist the blade in a cut.
- DO NOT transport a cutting machine with the blade mounted on the machine.
- DO NOT use a blade that has been dropped or damaged.
- DO NOT use carbide tipped blades.
- DO NOT lay power cords in or near water.
- DO NOT replace the motor with any motor that does not have a special grounding connection.
- DO NOT use segmented diamond blades without water unless specifically designed for dry cutting.
- DO NOT touch a dry cutting diamond blade immediately after use. These blades require several minutes to cool after each cut.
- DO NOT use damaged or worn blade flanges.
- DO NOT allow other persons to be near the machine when starting, refueling, or when the machine is in operation.
- DO NOT operate this machine in an enclosed area unless it is properly vented.
- DO NOT operate this machine in the vicinity of anything that is flammable. Sparks could cause a fire or an explosion.
- DO NOT allow blade exposure from the guard to be more than 80 degrees.
- DO NOT operate this machine with the belt guard or blade guard removed.
- DO NOT operate this machine unless you are specifically trained to do so.
- DO NOT use a blade that has been over heated (Core has a bluish color).
- DO NOT jam material into the blade.
- DO NOT grind on the side of the blade.

DO NOT start cutting with a saw until you have a clear work area and secure footing.
DO NOT operate this machine while under the influence of drugs or alcohol.



POTHIER ENTERPRISES LTD.

7221 - 72nd Street,
Tilbury Industrial Park,
Delta, B.C., Canada V4G 1M5

Telephone: (604) 946-3811

Fax: (604) 946-3788

email: sales@pothierenterprises.com

Web: www.pothierenterprises.com

BALDOR®

*For Warranty Information
on your Baldor motor or
for the nearest service center
please go to:*
www.baldor.com/support



POTHIER ENTERPRISES LTD.

7221 - 72nd Street,
Tilbury Industrial Park,
Delta, B.C., Canada V4G 1M5

Telephone: (604) 946-3811
Fax: (604) 946-3788
email: sales@pothierenterprises.com
Web: www.pothierenterprises.com

Pothier Enterprises Ltd. New Equipment Warranty

Except as noted below, Pothier Enterprises Ltd. warrants that its new equipment will be free from manufacturing defects for a period of 1 year from the date of purchase by the original consumer purchaser.

The above warranty is subject to the following exceptions:

1. To the extent the following components are part of any of the new equipment, Pothier Enterprises' warranty on the component parts is limited to the manufacturer's warranty period as set out below:

Gas Engines	Electric Motors	Water Pumps
Manufacturer Warranty Period	Manufacturer Warranty Period	Manufacturer Warranty Period
Honda Gas 2 Years	Baldor 1 Year	Beckett 1 Year
Lees	on..... 1 Year	Little Giant 1 Year

2. Pothier Enterprises Ltd.'s obligation under this warranty is expressly limited to the replacement or repair at Pothier Enterprises Ltd. in Delta, BC or at a service facility designated by Pothier Enterprises Ltd., of such part or parts as inspection shall disclose to have been defective. This warranty does not cover labour or maintenance items such as belts, filters, bearings and wheels. Purchaser is responsible for paying shipping costs to and from the location where the equipment is to be repaired or replaced. Motors and engines are to be serviced by the nearest authorized service centre, as designated by the manufacturer of the engine/motor. **Under no circumstances will Pothier Enterprises Ltd. be responsible for incidental or consequential damages.**
3. Pothier Enterprises Ltd.'s warranty does not apply to defects caused by damage, abuse, modifications, low voltage, acts of God, unreasonable use, faulty repairs made by others or defects caused by failure to provide reasonable maintenance. All warranties are void if the equipment or any of its components are altered or modified by the purchasers, or if the product is used in a manner or with a blade not recommended by the manufacturer.
4. The foregoing express warranties are in lieu of all other warranties. POTHIER ENTERPRISES LTD. EXPRESSLY DISCLAIMS ALL OTHER WARRANTIES, INCLUDING, WITHOUT LIMITATION, THE IMPLIED WARRANTIES OF MERCHANTABILITY AND FITNESS FOR A PARTICULAR PURPOSE.

FILL OUT CARD BELOW, CUT ON THE LINE, AND MAIL WITH COPY OF PROOF OF PURCHASE

Warranty – Registration Card

Description: _____

Model: _____ Serial Number: _____

_____ Horsepower: _____

_____ Motor Serial Number: _____

Purchased From (Company): _____

_____ Prov/State: _____

_____ Date Purchased: _____

Address: _____

Brand of Motor: _____

Motor Model No.:

City:

Purchasing Co.:

City: _____ Prov/State: _____ Postal/Zip Code: _____ Country: _____

Your Name: _____ Title: _____

Type of Business: _____